



BASO Gas Products LLC

BG1600M51EF-1AA Universal Intermittent Pilot Ignition Control

Application

The BG1600M51EF-1AA Universal Intermittent Pilot Ignition Control replaces many existing intermittent pilot ignition controls made by various manufacturers. It is a safety control designed for indirect burner ignition and supervision, for use with all gases and applicable to gas-fired appliances.

The BG1600M51EF-1AA is a microprocessor based ignition control. The microprocessor provides reliable software control of all timings and operates a diagnostic Light-Emitting Diode (LED). It provides ignition sequence, flame monitoring, and safety shutoff for intermittent pilot boilers, furnaces and other heating appliances. For a complete listing of specifications, refer to the *Technical Specifications* section.

Installation

Parts Included

The BG1600M51EF-1AA is supplied with a parts kit containing:

- 6 labels for marking wires
- 1/4" terminal for sense wire
- 3 wire nuts
- Rajah adapter described below

This control uses 1/4" quick connect terminals for spark connection. If existing cable uses Rajah or 1/4" female spark plug connector, use the adapter shown in Figure 1.

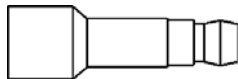

Figure 1: Rajah Adapter

IMPORTANT: Only qualified personnel should install or service BASO Gas Products®. These instructions are a guide for such personnel. Carefully follow all instructions for the appliance.

IMPORTANT: Make all gas installations in accordance with applicable local, national, and regional regulations.



WARNING: Risk of Explosion or Fire.

Do not install the control in an area that is exposed to water (for example, dripping, spraying, rain). Do not use the control if it has been exposed to water. Exposure to water may cause malfunction and can lead to an explosion or fire and may result in severe personal injury or death.

IMPORTANT: Verify that the control being replaced is in **Table 1** or confirm it is a suitable replacement using the specifications of the BG1600M51EF-1AA.

IMPORTANT: This control is approved for use with noise suppression (resistive) spark wires. If the application has copper wire, it must be replaced.

The BG1600M51EF-1AA replaces existing intermittent pilot ignition controls listed in Table 1 or controls with the following specifications:

- flame detection using flame rectification technology (ability of a flame to conduct and rectify current)
- Single rod (local sense) or dual rod (remote sense) flame sensing
- 100% shutoff/lockout with 5 minute continuous retry
- trial times of 25 seconds or longer
- prepurge period 1 second or less
- main burner 400,000 BTU/hr maximum
- pilot burners with flow rates of 1,500 Btu/hr or less
- with or without automatic vent damper
- must be used with redundant gas valves and not subjected to temperatures below -40°F (-40°C) or above 170°F (77°C)

Table 1: Replacement Part Numbers

Part Number	Original Manufacturer
S86A1001	Honeywell
S86A1019	Honeywell
S86A1027	Honeywell
S86A1035	Honeywell
S86B1017	Honeywell
S86B1025	Honeywell
S86C1007	Honeywell
S86C1015	Honeywell
S86C1031	Honeywell
S86C1049	Honeywell
S86C1056	Honeywell
S86D1005	Honeywell
S86D1021	Honeywell
S86E1002	Honeywell
S86E1010	Honeywell
S86E1028	Honeywell
S86E1036	Honeywell
S86E1044	Honeywell
S86E1051	Honeywell
S86E1069	Honeywell
S86E1077	Honeywell
S86E1101	Honeywell
S86E1119	Honeywell
S86E1127	Honeywell
S86F1000	Honeywell
S86F1018	Honeywell
S86F1026	Honeywell
S86F1042	Honeywell
S86F1059	Honeywell
S86F1067	Honeywell
S86F1075	Honeywell
S86F1083	Honeywell
S86F1091	Honeywell
S86G1008	Honeywell

Part Number	Original Manufacturer
S86G1016	Honeywell
S86G1032	Honeywell
S86G1057	Honeywell
S86G1073	Honeywell
S86H1006	Honeywell
S86H1022	Honeywell
S86H1048	Honeywell
S86H1055	Honeywell
S86H1089	Honeywell
S86H1097	Honeywell
S86H1105	Honeywell
S86H1121	Honeywell
S86H1147	Honeywell
S90A1005	Honeywell
S90B1003	Honeywell
S90B1011	Honeywell
S8600A1001	Honeywell
S8600B1009	Honeywell
S8600B3013	Honeywell
S8600C1015	Honeywell
S8600C3003	Honeywell
S8600F1000	Honeywell
S8600F1034	Honeywell
S8600F1042	Honeywell
S8600H1006	Honeywell
S8600H1022	Honeywell
S8600H1048	Honeywell
S8600H1055	Honeywell
S8600H1071	Honeywell
S8600H1089	Honeywell
S8600H1097	Honeywell
S8600H1105	Honeywell
S8600H3002	Honeywell
S8600M1005	Honeywell

Part Number	Original Manufacturer
S8600M1013	Honeywell
S8600M1021	Honeywell
S8600M1105	Honeywell
S8600M2003	Honeywell
S8600M3001	Honeywell
S8600M4009	Honeywell
S8610A1009	Honeywell
S8610B1007	Honeywell
S8610B1015	Honeywell
S8610C1005	Honeywell
S8610C1013	Honeywell
S8610C3001	Honeywell
S8610F1008	Honeywell
S8610F1016	Honeywell
S8610F1024	Honeywell
S8610F1032	Honeywell
S8610H1012	Honeywell
S8610H1038	Honeywell
S8610H1046	Honeywell
S8610H1053	Honeywell
S8610H1079	Honeywell
S8610H1095	Honeywell
S8610H3000	Honeywell
S8610H3026	Honeywell
S8610M1003	Honeywell
S8610M1029	Honeywell
S8610M3009	Honeywell
S8610U1003	Honeywell
S8610U1011	Honeywell
S8610U3009	Honeywell
S8620H1002	Honeywell
S8620H1028	Honeywell
CSA35A-617R	Johnson Controls
CSA35A-618R	Johnson Controls
CSA42A-600R	Johnson Controls

Part Number	Original Manufacturer
CSA42A-601R	Johnson Controls
CSA42A-602R	Johnson Controls
CSA42A-603R	Johnson Controls
CSA42A-604R	Johnson Controls
CSA43A-600R	Johnson Controls
CSA44A-600R	Johnson Controls
CSA45A-601R	Johnson Controls
CSA45A-602R	Johnson Controls
CSA46A-600R	Johnson Controls
CSA48A-600R	Johnson Controls
CSA49A-600R	Johnson Controls
CSA49A-605R	Johnson Controls
CSA51A-601R	Johnson Controls
CSA52A-600R	Johnson Controls
G600AX-1,2,3	Johnson Controls
G600AY-1	Johnson Controls
G600LX-1,2	Johnson Controls
G600LY-1	Johnson Controls
G600MX-1	Johnson Controls
G600NX-1	Johnson Controls
G600RX-1	Johnson Controls
G60AAA-1	Johnson Controls
G60AAG-1,2,3,4,5,6,7	Johnson Controls
G60CAA-1,3	Johnson Controls
G60CAG-1,2,3,4,5,6,7,8,9	Johnson Controls
G60CBA-1,2,3	Johnson Controls
G60CBG-1,2,3,4,5,6,7,8,9,10,11,12,13,14,15,16,17	Johnson Controls
G60CCA-1	Johnson Controls
G60CCG-1	Johnson Controls
G60CPG-1	Johnson Controls
G60DBG-1	Johnson Controls
G60DCG-1,2,3,4	Johnson Controls
G60GBA-1	Johnson Controls

Part Number	Original Manufacturer
G60GBG-1	Johnson Controls
G60KAG-1	Johnson Controls
G60PAG-1,2,3,4,5,6	Johnson Controls
G60PAJ-1	Johnson Controls
G60PAK-1,2	Johnson Controls
G60PFH-1,2	Johnson Controls
G60PVL-1	Johnson Controls
G60QAG-1,2,3,4	Johnson Controls
G60QAK-1	Johnson Controls
G60QBG-1,2,3,4,5,6,7,8,9	Johnson Controls
G60QBH-1	Johnson Controls
G60QBK-1,2,3	Johnson Controls
G60QBL-1,2	Johnson Controls
G60QCG-1	Johnson Controls
G60QCJ-1	Johnson Controls
G60QCL-1	Johnson Controls
G60QDG-1	Johnson Controls
G60QFL-1	Johnson Controls
G60QGH-1	Johnson Controls
G60QHL-1,2	Johnson Controls
G60QJL-1	Johnson Controls
G60QLG-1	Johnson Controls
G60QLK-1	Johnson Controls
G60QPG-1	Johnson Controls
G60QPK-1	Johnson Controls
G60QPL-1	Johnson Controls
G60QQJ-1	Johnson Controls
G60QRH-1,2,3	Johnson Controls
G60QRL-1,2,3	Johnson Controls
G60QSL-1	Johnson Controls
G60QTH-1	Johnson Controls
G60QTL-1	Johnson Controls
G60RAG-1	Johnson Controls
G60RBG-1,2,3	Johnson Controls

Part Number	Original Manufacturer
G60RBK-1,2	Johnson Controls
G60RCG-1,2	Johnson Controls
G60RCJ-1	Johnson Controls
G60RDG-1	Johnson Controls
G60RDK-1	Johnson Controls
G60RGL-1	Johnson Controls
G60RHL-1	Johnson Controls
G60RHP-1	Johnson Controls
G60RPL-1	Johnson Controls
G60RSL-1	Johnson Controls
G60ZAG-1,2	Johnson Controls
G65BBG-1 through 8	Johnson Controls
G65BBM-1,2,3,4	Johnson Controls
G65BCG-1	Johnson Controls
G65BCM-1	Johnson Controls
G65BFG-1	Johnson Controls
G65BKG-1,2,3	Johnson Controls
G65BKM-1,2,3	Johnson Controls
G65BLG-1,2	Johnson Controls
G65DBM-1,2,3	Johnson Controls
G65DCM-1	Johnson Controls
G65DFM-1	Johnson Controls
G65DKM-1	Johnson Controls
G65DLM-1	Johnson Controls
G66AG-1,2	Johnson Controls
G66BG-1	Johnson Controls
G66MG-1,2	Johnson Controls
G66NG-1	Johnson Controls
G670AW-1, 2	Johnson Controls
G67AG-3,4,7,8,9,10,11	Johnson Controls
G67BG-2,3,4,5	Johnson Controls
G67MG-1,2,3,4	Johnson Controls
G67NG-2,4	Johnson Controls
G770LGA-1,2	Johnson Controls
G770LGC-1,2,3,4	Johnson Controls

Part Number	Original Manufacturer
G770LHA-1,2	Johnson Controls
G770LHC-1	Johnson Controls
G770MGA-1,2,3	Johnson Controls
G770MGC-1,2,3,4,5,6	Johnson Controls
G770MHA-1,2	Johnson Controls
G770MHC-1	Johnson Controls
G770NGA-1	Johnson Controls
G770NGC-4,5,6,7	Johnson Controls
G770NHA-1	Johnson Controls
G770NHC-1	Johnson Controls
G770RGA-1,2,3	Johnson Controls
G770RHA-1,2	Johnson Controls
G775RGA-1	Johnson Controls
G775RHA-1,2	Johnson Controls
G775RJA-1	Johnson Controls
G779LHA-1	Johnson Controls
Y79ABC-1 through 7	Johnson Controls
Y79ABD-1,2	Johnson Controls
Y79BBA-1,2	Johnson Controls

Part Number	Original Manufacturer
780-001	Robertshaw
780-002	Robertshaw
780-715	Robertshaw
780-735	Robertshaw
780-736	Robertshaw
780-737	Robertshaw
780-845	Robertshaw
SP715	Robertshaw
SP715A	Robertshaw
SP735	Robertshaw
SP735D	Robertshaw
SP735L	Robertshaw
50D49-350	White-Rodgers
50D49-360	White-Rodgers
IPI-24-00	Camstat
05-203025-005	Fenwal
05-203026-005	Fenwal
1003-3	HSC
1003-300	HSC

Replacing the Existing Ignition Control



CAUTION: Risk of Electric Shock.

Disconnect power supply before making electrical connections to avoid electric shock.



WARNING: Risk of Explosion or Fire.

Shut off the gas supply at the main manual shutoff valve before installing or servicing the control. Failure to shut off the gas supply can result in the release of gas during installation or servicing, which can lead to an explosion or fire, and may result in severe personal injury or death.



WARNING: Risk of Explosion, Fire, or Electric Shock. Label all wires before they are disconnected when replacing or servicing the BG1600M51EF-1AA. Wiring errors can cause improper or dangerous operation and may result in an explosion, fire, or electric shock leading to severe personal injury or death.

To remove the existing ignition control:

1. Shut off power to the appliance.
2. Turn off the gas at the main manual shutoff valve adjacent to the appliance. (If the manual shutoff valve services more than one appliance, be sure to light the other pilots before leaving the installation.)
3. Label each wire with the correct terminal designation prior to disconnection, using the labels provided with the parts kit.
4. Disconnect the wires from the existing control.
5. Disconnect the vent damper plug/cable (if used) from the ignition control.
6. Remove the screws holding the ignition control to the valve (if direct valve-mount model) or remove the screws holding the control to the appliance chassis (if foot-mount model).
7. Remove the old ignition control and discard.

IMPORTANT:

Do not mount the control where it can be exposed to direct infrared radiation from the main burner or to temperatures in excess of the maximum product temperature rating.

8. Mount the new control with #6 sheet metal or machine screws through the mounting holes in the enclosure.
9. Refer to the *Wiring* section for electrical connections and wiring diagrams. Perform the *Checkout* section before leaving the installation.
10. Check all wiring for proper connections and make sure your system is properly grounded, including the pilot burner igniter.

Note: The BG1600M51EF-1AA is **NOT** designed to replace ignition controls with the following specifications:

- pilot flame detection by any means other than flame rectification
- trial for ignition period of less than 25 seconds
- prepurge greater than 4 seconds
- standing pilot applications

Wiring



WARNING: Risk of Explosion or Fire.

Locate all safety, limit, and operating controls in series with the thermostat terminal (TH) on the ignition control. Improper installation may cause gas leaks, which can lead to an explosion or fire and may result in severe personal injury or death.

Refer to Figure 2 through Figure 5 for wiring diagrams. All wiring should be in accordance with the National Electrical Code (NEC) and all other local codes and regulations.

Check the voltage rating marked on the control and make sure it is suited to the application. Use a Class 2 transformer capable of providing 24 VAC under maximum load, including valves. A transformer having excessive primary impedance due to poor coupling affects the ignition potential.

The high-voltage spark transformer cable is noise suppression (resistive) type rated for at least 15kV and must not be in continuous contact with a metal surface. Use standoff insulators. Ensure that the flame sensor wire and high voltage spark transformer cable are separated from one another by a minimum of 1/4 in. (6.35 mm) and are not wrapped around any pipe, other wiring, or accessories.

The control is supplied with a jumper wire between Sense and Internal terminals and is ready for internal (one rod) flame sense. With the jumper in, flame is sensed through the high voltage spark wire. The jumper must be removed for external (two rod) flame sense and the sense electrode wired to the Sense terminal.

Note: A shorting plug that jumpers pins 2 and 3 of the damper connector is supplied with the control. The shorting plug must be used if a vent damper is not used. When a vent damper has been connected and power turned on, an internal fuse in the control will blow and the control will only operate with a vent damper connected. Now you cannot disconnect the vent damper plug and put back the shorting plug. The ignition control will not work.



WARNING: Risk of Electric Shock.

Before applying power to the control, connect the high voltage cable to the spark transformer terminal and spark electrode (pilot burner assembly). Verify the ground wire is attached to the pilot burner and the control ground terminal strip. Failure to follow this procedure can cause electric shock and may result in severe personal injury or death.

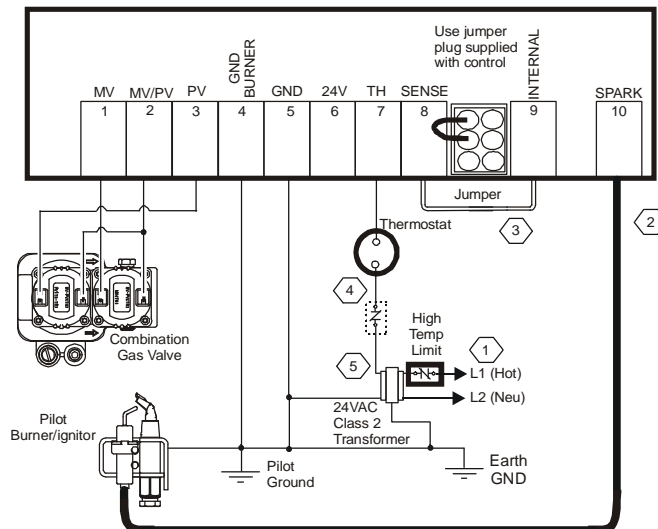

- ① Power Supply. Provides disconnect means and overload protection as required.
- ② Maximum cable length 48 inches (1,220 mm). (Resistive wire recommended.)
- ③ For single rod application, leave jumper wire in as received.
- ④ Alternate location for limit controller.
- ⑤ Controls in 24V circuit must not be in ground leg to transformer.

Figure 2: Wiring for 1 Rod Flame Sense without Vent Damper

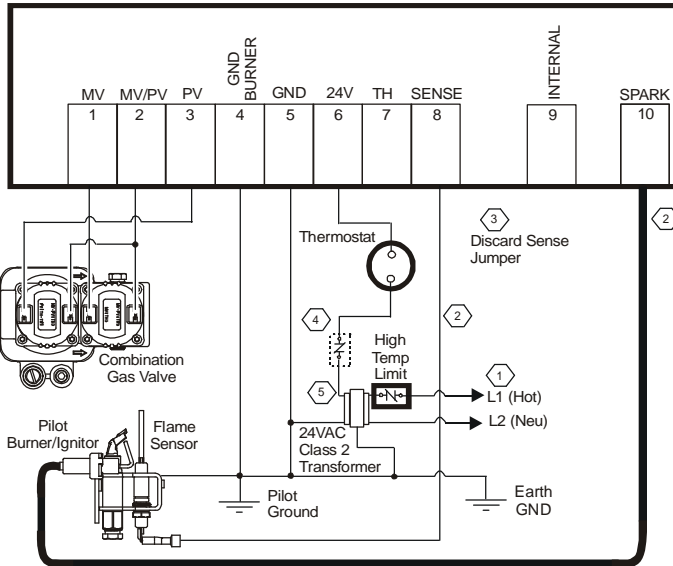

- ① Power Supply. Provides disconnect means and overload protection as required.
- ② Maximum cable length 48 inches (1,220 mm). (Resistive wire recommended.)
- ③ For two rod application, remove jumper wire before installation.
- ④ Alternate location for limit controller.
- ⑤ Controls in 24V circuit must not be in ground leg to transformer.

Figure 3: Wiring for 2 Rod Flame Sense without Vent Damper

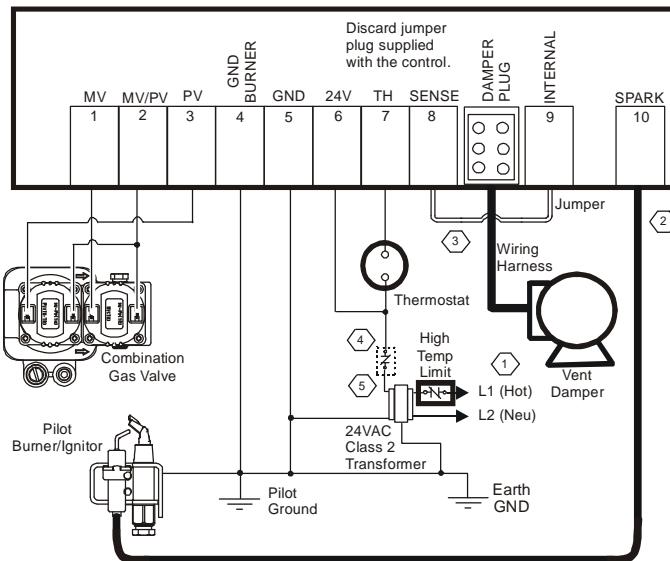

- ① Power Supply. Provides disconnect means and overload protection as required.
- ② Maximum cable length 48 inches (1,220 mm). (Resistive wire recommended.)
- ③ For single rod application, leave jumper wire in as received.
- ④ Alternate location for limit controller.
- ⑤ Controls in 24V circuit must not be in ground leg to transformer.

Figure 4: Wiring for 1 Rod Flame Sense with Vent Damper

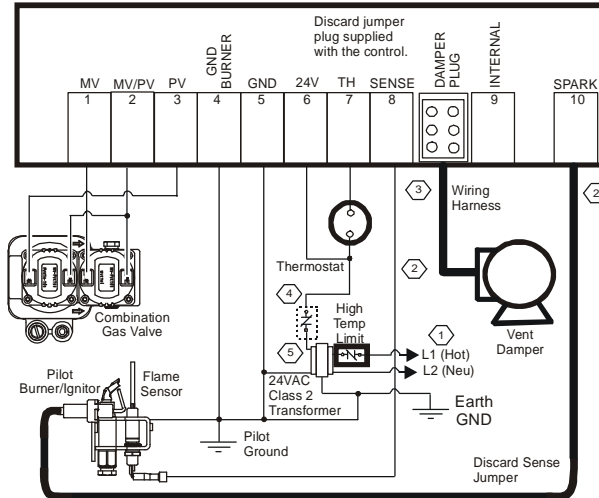

- ① Power Supply. Provides disconnect means and overload protection as required.
- ② Maximum cable length 48 inches (1,220 mm). (Resistive wire recommended.)
- ③ For two rod applications remove jumper wire before installation.
- ④ Alternate location for limit controller.
- ⑤ Controls in 24V circuit must not be in ground leg to transformer.

Figure 5: Wiring for 2 Rod Flame Sense with Vent Damper

Setup and Adjustments

Instructions for Specific Models

Follow the instructions below for replacement of specific control models.

Replacing Honeywell® S8610U1003 and S86xx Controls

The BG1600M51EF-1AA control has 1/4 inch terminals whose general locations and labels match the S8610U1003 and other S86xx controls. If a two rod flame sense is used, the 3/16 inch terminal on the flame sense wire must be replaced with the 1/4 inch terminal provided in the parts kit. Verify that the spark wire is noise suppression (resistive) type and replace if necessary.

Replacing Johnson Controls® G600AX-1 and G600LX-1

The G600AX-1 and G600LX-1 use the same terminal numbers as the G77x without text labels. Use the Rajah spark adapter included in the parts kit. Verify that the spark wire is noise suppression (resistive) type and replace if necessary.

Replacing Johnson Controls® G779LHA-1 and G77x

Wire Function	G77x	BG1600M
Main Valve	3 MV	1 MV
Valve Common	Ground Plate	2 MV/PV
Pilot Valve	1 PV	3 PV
Pilot Burner Ground	Ground Plate	4 GND (BURNER)
Power Supply Ground	Ground Plate	5 GND
24VAC Power (if damper is used)	6 24V	6 24V
Thermostat	2 THS	7 TH
Sense Electrode (if two rod sense)	4 SENSE	8 SENSE

If the G77x uses a spike type high voltage connector. It will be necessary to replace the spark cable assembly.

Replacing Robertshaw® 780-845

Wire Function	780-845	BG1600M
Main Valve	MV	1 MV
Valve Common	PV-MV	2 MV/PV
Pilot Valve	PV	3 PV
Pilot Burner Ground	GND	4 GND (BURNER)
Power Supply Ground	TR	5 GND
Thermostat	TH	7 TH
Sense Electrode (if two rod sense)	SENSE	8 SENSE

Note: Verify that the spark wire is noise suppression (resistive) type and replace if necessary.

Checkout



WARNING: Risk of Explosion or Fire.

Verify that there are no gas leaks by testing with appropriate equipment. Never use a match or lighter to test for the presence of gas. Failure to test properly can lead to an explosion or fire and may result in severe personal injury or death.

Make sure all components function properly by performing the following test.

1. Before starting the appliance, perform a safety inspection of piping, burners and venting. Check for water leaks, etc. Check all wiring for proper connections. Be sure the system is properly grounded, including ground connection to the pilot burner.
2. With the gas and thermostat off, turn on power to the appliance.
3. Turn the thermostat to a high setting and verify that the control goes through the operating sequence to a shutoff condition.

Note: The burner does not light because the gas is off.
4. Turn off the thermostat.
5. Turn on the gas and purge gas lines of all air.
6. Check for gas leaks on all pipe joints upstream of the gas valve with a soap solution.
7. Turn the thermostat to the highest setting and verify successful ignition and a normal run condition for at least 5 minutes. If the appliance fails to run, see the *Troubleshooting* section.

8. Check for gas leaks on all pipe joints downstream of the gas valve with a soap solution.
9. Turn the thermostat down for at least 30 seconds and then back up again. Verify successful ignition at least five times.
10. Return the thermostat to a normal temperature setting before leaving the installation.



WARNING:

The control module can not be serviced by user. If any faults are detected, the control module must be replaced. If control module has been opened or any attempts to repair are done, the warranty is void.

Operation

Operating Mode Definitions

The following definitions describe the BG1600M51EF-1AA operating conditions.

- **Prepurge:** Initial time delay between thermostat contact closure and activation of the spark circuit and pilot valve.
- **Trial for Ignition:** Total time the pilot valve is energized and spark/sense sequence is activated in an attempt to light the pilot. The control attempts to prove flame within the trial-for-ignition time.
- **100% Shutoff:** If the control does not prove the presence of pilot burner flame within the trial for ignition, the spark circuit and pilot valve are de-energized.
- **Recycle:** If 100% shutoff occurs, the control delays 5 minutes (recycle delay period) and begins another trial for ignition.
- **Run:** Main valve is energized and spark turns off after pilot flame is proven. The main valve remains energized until the thermostat is satisfied.
- **Flameout:** Loss of proven flame. Should a flameout occur, the main valve de-energizes and spark recurs within 2.0 seconds.
- **Lockout:** An internal or external fault has caused the control to de-energize the spark circuit and valve relays. The thermostat contacts must be opened for 30 seconds and then closed to begin another trial for ignition.
- **Inter-Purge:** Period between trials for ignition when both the gas valve and spark are de-activated to allow unburned gas to escape before the next trial.

Sequence of Operation

The heating cycle starts when a call for heat from the thermostat supplies 24VAC to the TH terminal. The automatic vent damper (if used) is energized and when fully open, turns on the power to the ignition control. After a 1 second maximum diagnostic period, the spark will start and the pilot valve will turn on, starting the trial for ignition period.

During the trial for ignition period, the control sparks for 4 seconds while rapidly flashing LED. It then turns off the spark and LED for 1 second while checking pilot flame sense. This cycle will repeat until pilot flame is detected or trial time is over.

When pilot flame is detected, the spark will stop, main valve will turn on and the LED will stay on continuously. The control will remain in this state until the pilot flame is lost or the call for heat ends. If pilot flame is lost, LED, main and pilot valves are turned off for 0.5 seconds and a new trial for ignition sequence will start.

If pilot flame is not detected during the trial for ignition period, the pilot valve will be shut off. The control will wait for 5 minutes while blinking the LED at the end of each 15 seconds. When the 5 minute period is over a new trial for ignition sequence will start. The control will recycle continuously until flame is proven or call for heat ends.

Table 2: LED Indications During Normal Operation

Flash Code	Flash Code Indication
Steady On	Flame detected, main burner on
.1 Second On .1 Second Off	Trial time spark on trying to light pilot burner
.5 Second Every 15 Seconds	In 5 minute recycle period

Troubleshooting

If the system does not function properly, determine the cause using the procedures in this section.

Before proceeding with troubleshooting the system, check the following.

Preliminary Checks

- Are all mechanical and electrical connections tight?
- Is the system wired and ground correctly?
- Is gas inlet pressure per manufacturer's specifications?
- Is the system powered?
- Is the thermostat calling for heat?

LED Error Indications

If the control module internal diagnostics detect a fault it will go to lockout. Spark and both valves will be turned off. The LED will flash the error code .25 seconds on and .25 seconds off for each count of the error code with 1 second off between codes. The control will remain in this condition until power is removed by turning off the call for heat. Codes indicate a problem with the control and it must be replaced.

Table 3: LED Error Indications

Flash Code	Flash Code Description
1	No flame in trial time
2	Flame sense circuit error
3	Pilot valve circuit error
4	Main valve circuit error
5 to 9	Internal control error



WARNING: Risk of Personal Injury.

Do not place face, hands, or other parts of the body in or near the burner area when the LED is flashing (recycle mode). When the LED is flashing, the control may at any time (while in the recycle mode) re-energize the burner control system and ignite the burner which may result in electric shock from contact with the electrode or severe burn injury from firing of the burner.

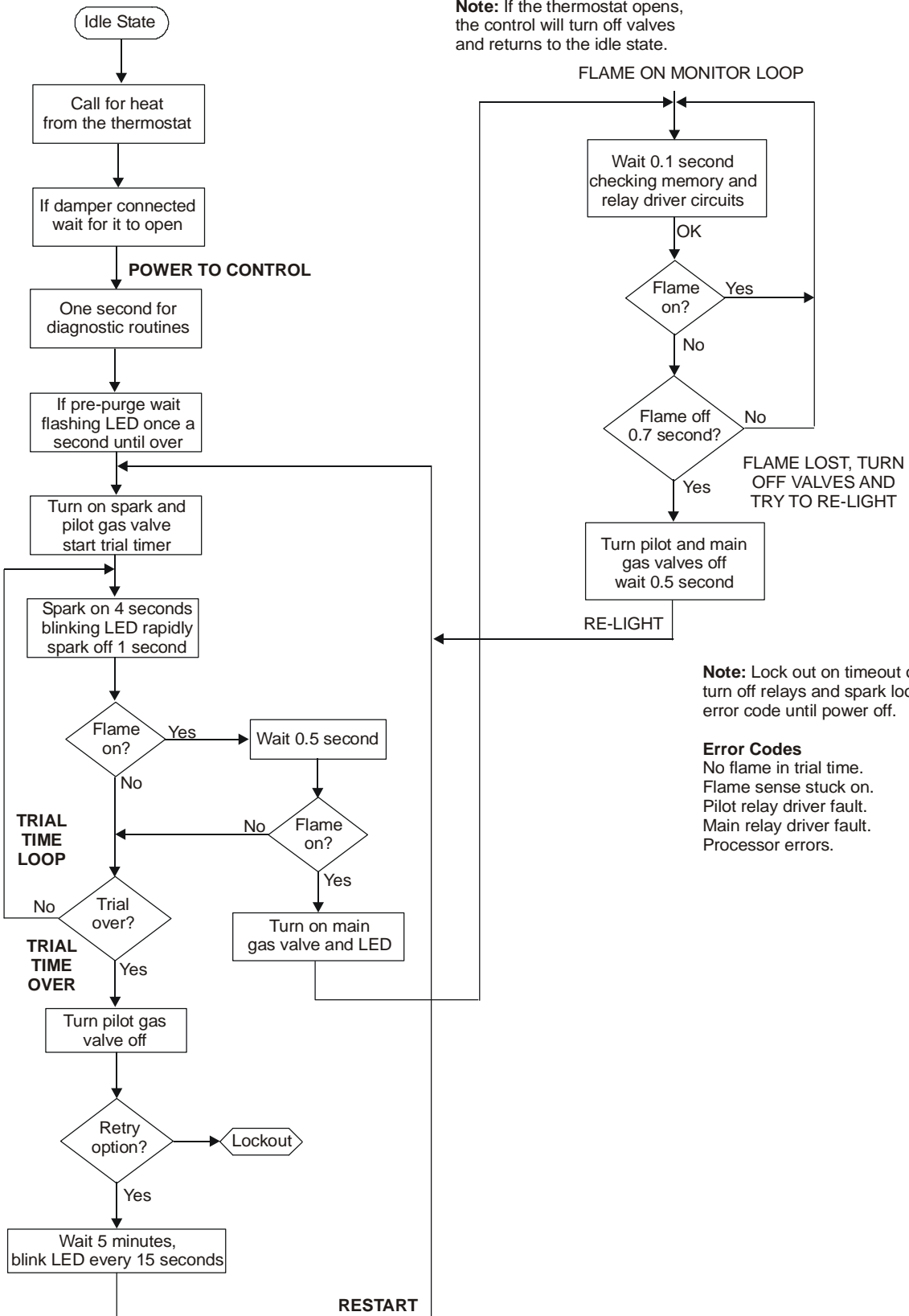

Figure 6: Sequence of Operation

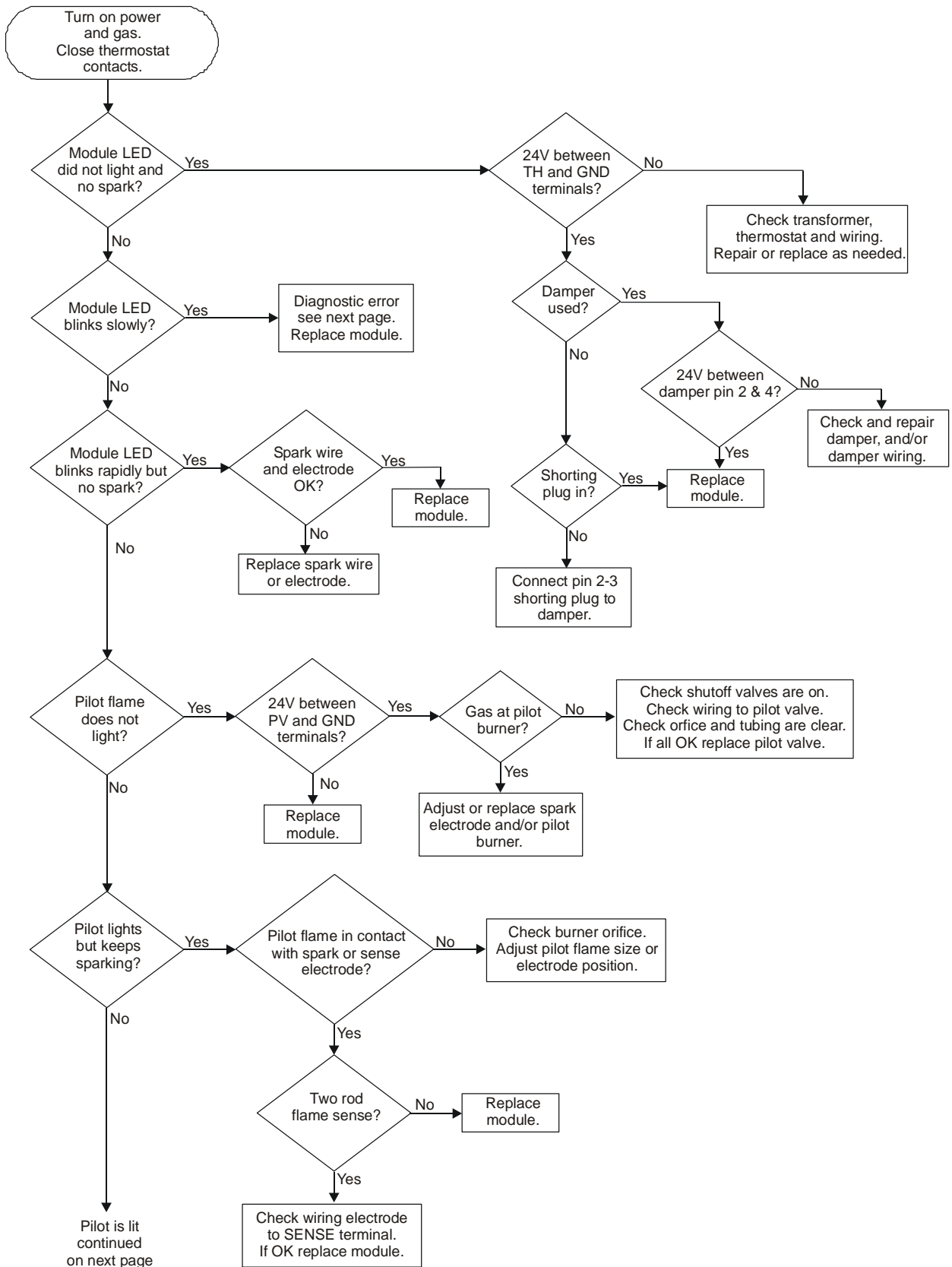

Figure 7: Troubleshooting Flow Chart (1 of 2)

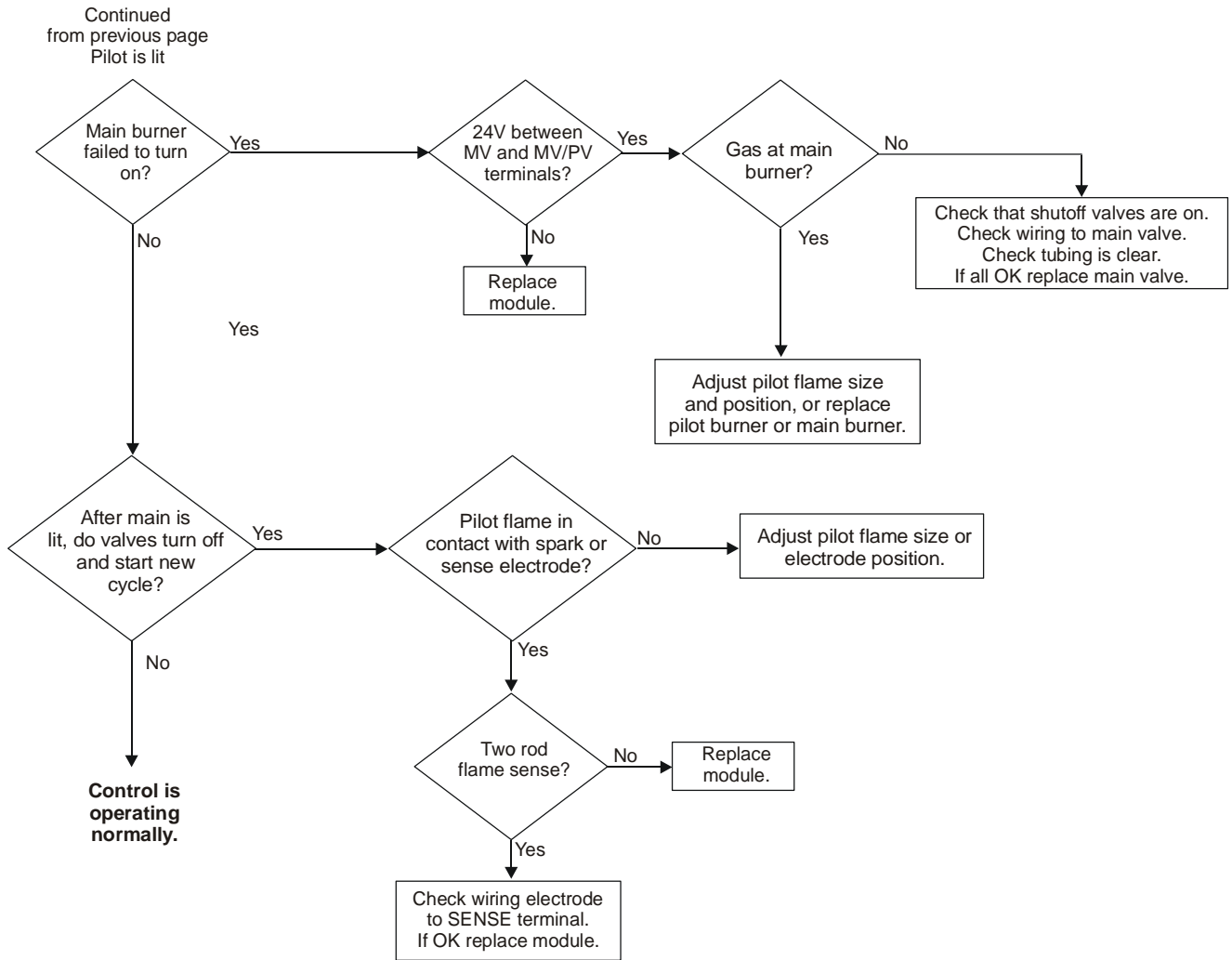

Figure 8: Troubleshooting Flow Chart (2 of 2)

Cut out and leave near control.

LED Indications During Normal Operation	
Steady On	Flame detected, main burner on
.1 Second On, .1 Second Off	Trial time spark on trying to light pilot burner
.5 Second Every 15 Seconds	In 5 minute recycle period
LED Error Indications .25 Second On and .25 Second Off	
1	No flame in trial time
2	Flame sense circuit error
3	Pilot valve circuit error
4	Main valve circuit error
5 to 9	Internal control error

Maintenance Requirements in Severe Environments

Regular preventive maintenance is important in any application, but especially so in commercial cooking, agricultural, and industrial applications because:

- In many such applications, particularly commercial cooking, the equipment operates 100,000 to 200,000 cycles per year. Such heavy cycling can wear out the gas control in one to two years. A normal forced air furnace, for which the controls were originally intended, typically operates less than 20,000 cycles per year.
- Exposure to water, dirt, chemicals, and heat can damage the ignition control module or the gas control and shut down the control system. A NEMA 4 enclosure can reduce exposure to environmental contaminants.



WARNING: Risk of Explosion or Fire. Do not attempt to take the ignition control module apart or to clean it. Improper reassembly and cleaning may cause unreliable operation, which can lead to an explosion or fire, and may result in severe injury, property damage or death.

Maintenance frequency must be determined individually for each application. Some considerations are:

- Cycling Frequency – Appliances that may cycle more than 20,000 times annually should be checked monthly.
- Intermittent Use – Appliances that are used seasonally should be checked before shutdown and again before the next use.
- Consequence of Unexpected Shutdown – Where the cost of an unexpected shutdown would be high, the system should be checked more often.
- Dust, Wet, or Corrosive Environment – Since these environments can cause the controls to deteriorate more rapidly, the system should be checked more often.

Repairs and Replacement



CAUTION: Risk of Electric Shock.
Disconnect power supply before making electrical connections to avoid electric shock.



WARNING: Risk of Explosion or Fire.
Shut off the gas supply at the main manual shutoff valve before installing or servicing the control. Failure to shut off the gas supply can result in the release of gas during installation or servicing, which can lead to an explosion or fire, and may result in severe injury or death.



WARNING: Risk of Explosion, Fire, or Electric Shock. Label all wires before they are disconnected when replacing or servicing the BG1600M51EF-1AA. Wiring errors can cause improper or dangerous operation and may result in an explosion, fire, or electric shock leading to severe personal injury or death.

Field repairs must not be made to the BG1600M51EF-1AA control. Any attempt to repair this assembly voids the manufacturer's warranty. For a replacement control, contact the original equipment manufacturer or the nearest BASO Gas Products distributor.

All other accessories, such as flame sensors, electrode assemblies, pilot assemblies, and leads can be obtained through the original equipment manufacturer or a BASO Gas Products distributor.

Technical Specification

Product	BG1600M51EF-1AA Universal Intermittent Pilot Ignition Control	
Ignition Type	Indirect	
Ignition Source	High voltage spark, capacitive discharge	
High Voltage Cable Maximum Length	48 in. (1,220 mm) (Resistive wire recommended, rated for at least 15Kv.)	
Flame Sense Cable Maximum Length	48 in. (1,220 mm)	
Flame Detection Means	Flame Rectification	
Flame Detection Type	Local or Remote	
Minimum Flame Current	0.15 microamperes	
Flame Failure Response Time	2 seconds maximum	
Maximum Spark Gap	0.2 in. (5.1 mm)	
Number of Trials Before 100% Shutoff	One	
Trial-for-Ignition Time	25 seconds then 100% shutoff (pilot and main gas)	
Prepurge Time	1 second maximum	
Automatic Recycle Delay Period	5 minutes	
Power Requirements	Control:	24 VAC (+/- 20%), 50/60 Hz
	Operation Current:	0.2 A nominal + valves
Contact Rating	Main Valve:	2 A maximum
	Pilot Valve:	1 A maximum
Wiring Connections	1/4 in. (6.35 mm) male spade	
Maximum Firing Rate	400,000 Btu/hr (117 kW)	
Ambient Operating and Storage Temperature	-40 to 170°F (-40 to 77°C)	
Humidity	95% RH noncondensing	
Type of Gas	Natural, Liquefied Petroleum (LP), Manufactured, Mixed or LP Gas-Air Mixture	
Packaging	Bulk pack supplied to original equipment manufacturer (individual pack [-1AAC] or individual overpack [-1AAE, 20 per box] optional)	
Bulk Pack Quantity	25	
Pack Weight	Bulk pack (-1AAD) 14 lb (6.36 kg) Individual pack (-1AAC) 1 lb (.454 kg) Individual overpack (-1AAE) 18 lb (8.17 kg)	
Agency Listing	CSA Certificate Number 246569-2161442	
Specifications Standards	ANSI Standard Z21.20 CAN/CSA-C22.2 No. 199	

The performance specifications are nominal and conform to acceptable industry standards. All agency certification of BASO products is performed under dry and controlled indoor environmental conditions. Use of BASO products beyond these conditions is not recommended and may void the warranty. If the product is exposed to water (dripping, spraying, rain, etc.) or other harsh environments, it must be protected. The original equipment manufacturer or end user is responsible for the correct application of BASO products. For questionable applications, please consult BASO Gas Products LLC. BASO Gas Products LLC shall not be liable for damages or product malfunctions resulting from misapplication or misuse of its products.

1007 South 12th Street
PO Box 170
Watertown, WI 53094
1-877-227-6427

Published in U.S.A.
www.baso.com